

IBS  
IMPLANT Different, but Better  
It's time to change

---

# MAGICORE SYSTEM

for minimally invasive implant surgery

---

## INTRODUCTION

# It's time to change

We've come to a time in modern implantology where various treatment techniques are now developed and can be applied to fit any clinical situation with successful outcomes.

However, whilst treating our patients, we seem to have neglected to develop treatments that reduce the damage done to them, even more so, than during the times of Branemark's bone focused implants.

It follows that the direction modern implant treatments must go is toward development and research into treatment methods that reduce the damage done to soft tissue and bone, while also minimizing the use of artificial and exogenous materials.

Since 2003, IBS Implant has been researching this very endeavor, and has reached a level of technology that enables the design and production of a system that is specific and optimal for minimally invasive implant treatments.

IBS Implant will not stop at merely being recognized as an outstanding implant system. We will continually do our best in providing the world with an implant system that is desired and needed by clinicians and patients for centuries to come.

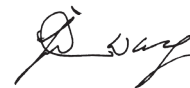

Je-Won Wang D.D.S., M.S.  
CEO  
INNOBIOSURG CO.



IBS  
IMPLANT

Optimized for Minimally Invasive Surgery  
**MAGICORE®**



# CONTENTS

---

History of IBS Implant	03
MagiCore (Product Specification)	07
MagiCore KIT	17
MagiCore (Surgical Protocol)	26

# History of IBS Implant

**2003**

- Start of research for minimally invasive implant system

**2007**

- Magic Surgical System developed

**2008**

- A new implant and surgical system developed for minimally invasive surgery
- IBS Implant HQ established

**2009**

- Manufacturing plant established
- Recognized as venture company
- KFDA certified

**2011**

- Magic Kit FDA certified
- Pakistan, Iran, Turkey distribution begins
- Research institute established

**2012**

- Recognized as promising start-up by Korean National Government
- Malaysia, Vietnam, Philippines distribution begins

**2013**

- MOU with Wonkwang University Osteogenesis Research Center
- First IBS Implant World Symposium held
- HQ expansion
- Greece, Spain, UAE, India, Egypt distribution begins

**2014**

- MOU with Wonkwang University
- China NMPA Certified
- Bulgaria, Iraq, Czech Rep., Italy, Chile distribution begins

## 2015

- 2nd IBS Implant World Symposium held in Antalya, Turkey
- GOST-R Russia Certified
- U.S.A subsidiary established
- Poland, Germany, Thailand, Kyrgyzstan, France, Indonesia distribution begins
- 11 national field offices established
- FDA Class II Certified
- Japan PMDA Certified
- Fatigue test machine acquired

## 2016

- 12 national field offices in place
- Distribution in 40 nations throughout Asia, Europe, and Middle East
- China subsidiary established
- Europe subsidiary established
- MOU with SSPM Dental University in Russia
- MOU with Mustansiria University in Iraq
- U.S.A. Clinical Training Center established
- Monthly Training Courses held in U.S.A.
- 1st IBS Europe meeting held
- 1st IBS Implant Turkey Congress held
- 3rd IBS Implant World Symposium held in Korea
- India, Taiwan, Thailand product registrations certified
- IBS Clinical Research Institute established

## 2017

- SEM machine acquired
- India DCG certified
- Taiwan TFDA certified
- Academy of Minimally Invasive Implantology (AMII) established
- 3rd AMII national course completed

## 2018

- Kazakhstan GOST-K certified
- China factory established
- 4th IBS Implant World Symposium held in Seoul
- 11th AMII Training Course completed
- Laser Marking Machine acquired
- Laser Welding Machine acquired
- 6 additional CNC machines acquired

## 2019

- Vietnam, Thailand, subsidiary establishment planned
- MOU with 3 additional major international universities planned
- Bi-annual Symposium in major cities planned
- 5th AMII World Symposium planned (November)
- 21st AMII Training Course completion planned

## 2020~2021

- U.S.A factory establishment planned
- Japan, India, UAE, Africa subsidiaries planned
- MOUs with 7 additional major int'l universities planned
- Yearly IBS user meetings planned
- Yearly AMII World Symposium planned
- Quarterly Research meetings planned
- Korea, USA, Europe, and Russia expansion of AMII and research activities
- 3rd Main factory establishment planned

# | WORLDWIDE LOCATIONS

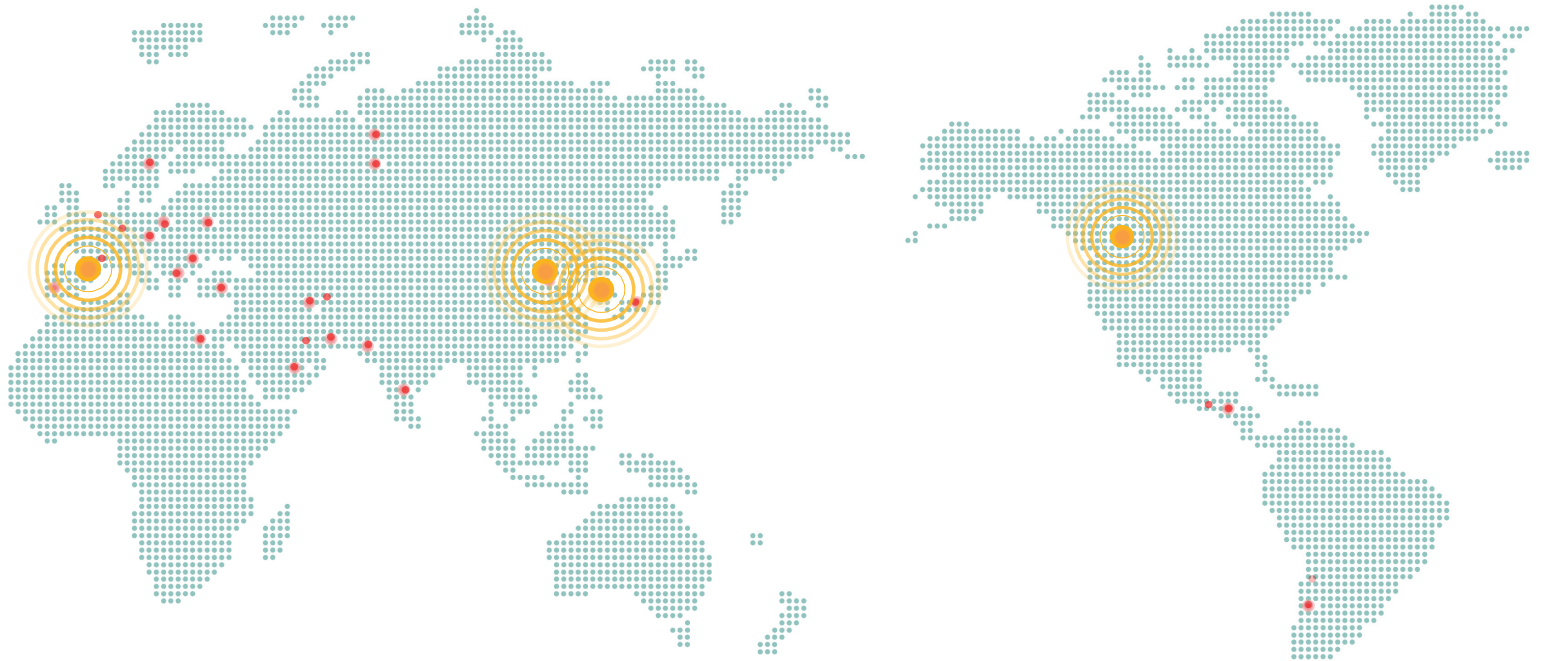

INNOBIOSURG HQ, KOREA.



INNOBIOSURG OF AMERICA.



INNOBIOSURG OF EUROPE.



INNOBIOSURG OF CHINA.

- France
- Hungary
- Bulgaria
- Chile
- Czech Republic
- Egypt

- Iraq
- Japan
- Kosovo
- Kyrgyzstan
- Poland
- Philippines

- Greece
- Pakistan
- Guatemala
- India
- Indonesia
- Iran

- Russia
- Spain
- Turkey
- Thailand
- U.A.E
- U.K

# International Recognition

- Recognized for the creation of the new 4th original paradigm of implant design.
- Recognized by pioneering nations such as the US, Europe, etc. as Korea's first Premium Brand Implant.
- Asia's first brand to be in mutual research activities with European universities on minimally invasive implant surgery.

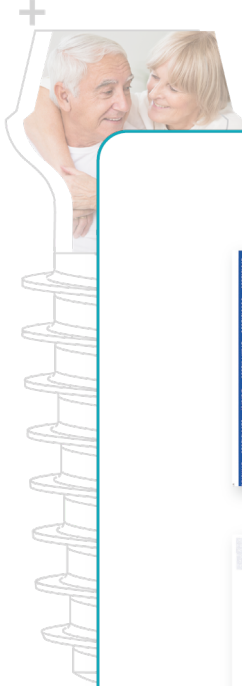

## CERTIFICATES



The World's 4th Paradigm of Original Implant Design  
The World's 1st **Minimally Invasive Implant**

# MAGICORE<sup>®</sup>

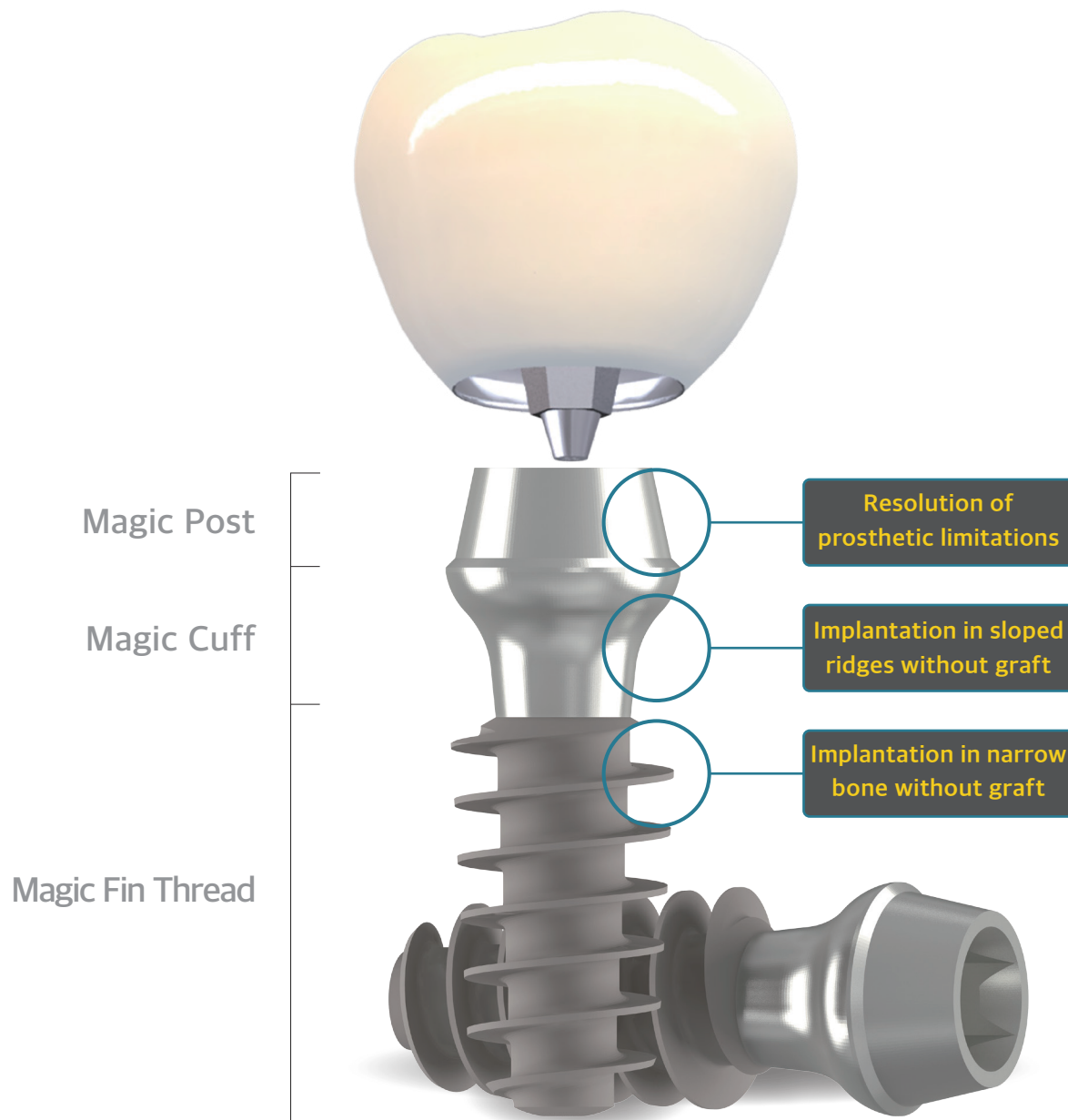

Prestige Award Winner for "Most Innovative Patent"

Korean National Ministry of Science and Technology

(Patents: 10-1586082, 10-1388846)

# Prosthetic Flow for MAGICORE®

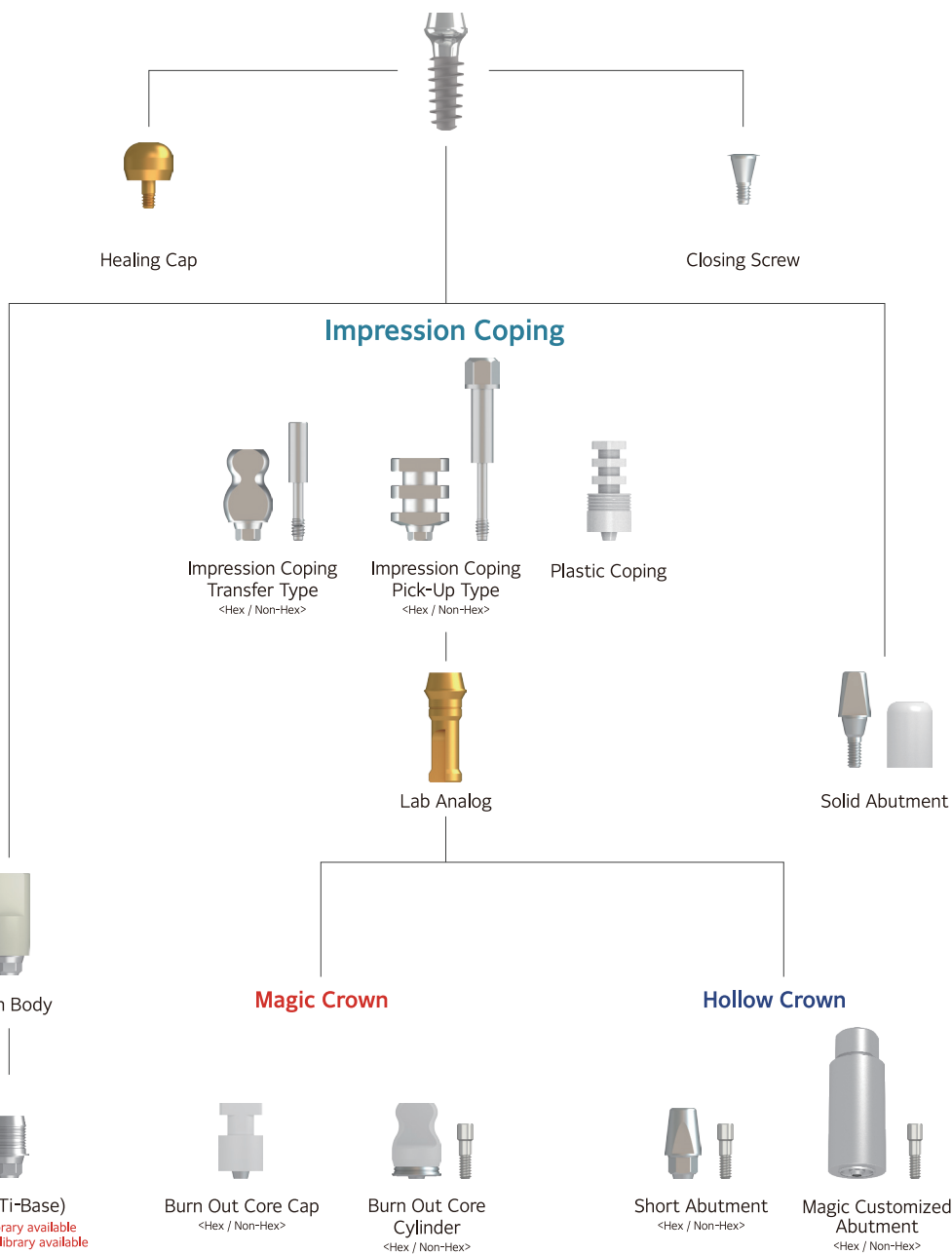

## MagiCore Narrow Fixture (uses Ø4.0 abutment)

### Fixture Size

Fixture Diameter Ø3.0

[mm]

Fixture Part		
Diameter(D)	Length(L)	Magic Cuff
Ø3.0	11	2
		3
		4
		5
	13	2
		3
		4
		5
	15	2
		3
		4
		5

Code	Cuff(C)
401M3011	1
402M3011	2
403M3011	3
404M3011	4
401M3013	1
402M3013	2
403M3013	3
404M3013	4
401M3015	1
402M3015	2
403M3015	3
404M3015	4

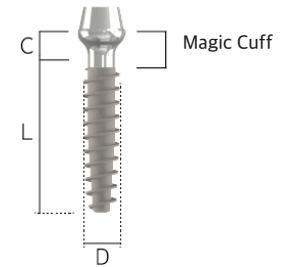

■ Available in selected regions only

Fixture Diameter Ø3.5

[mm]

Fixture Part		
Diameter(D)	Length(L)	Magic Cuff
Ø3.5	11	2
		3
		4
		5
	13	2
		3
		4
		5
	15	2
		3
		4
		5

Code	Cuff(C)
401M3511	1
402M3511	2
403M3511	3
404M3511	4
401M3513	1
402M3513	2
403M3513	3
404M3513	4
401M3515	1
402M3515	2
403M3515	3
404M3515	4

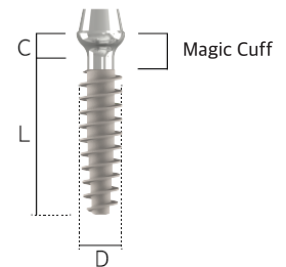

■ Available in selected regions only

## MagiCore Fixture (uses Ø4.5 abutment)

### Fixture Size

Fixture Diameter Ø4.0

[mm]

Fixture Part		
Diameter(D)	Length(L)	Magic Cuff
Ø4.0	9	2
		3
		4
		5
	11	2
		3
		4
		5
	13	2
		3
		4
		5

Code	Cuff(C)
451M4009	1
452M4009	2
453M4009	3
454M4009	4
451M4011	1
452M4011	2
453M4011	3
454M4011	4
451M4013	1
452M4013	2
453M4013	3
454M4013	4

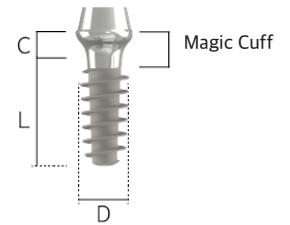

Fixture Diameter Ø4.5

[mm]

Fixture Part		
Diameter(D)	Length(L)	Magic Cuff
Ø4.5	7	2
		3
		4
		5
	9	2
		3
		4
		5
	11	2
		3
		4
		5
	13	2
		3
		4
		5

Code	Cuff(C)
451M4507	1
452M4507	2
453M4507	3
454M4507	4
451M4509	1
452M4509	2
453M4509	3
454M4509	4
451M4511	1
452M4511	2
453M4511	3
454M4511	4
451M4513	1
452M4513	2
453M4513	3
454M4513	4

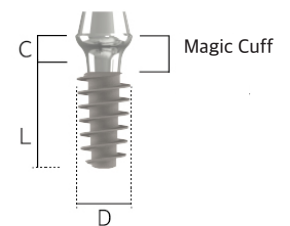

## MagiCore Fixture (uses Ø5.5 Abutment)

### Fixture Size

Fixture Diameter Ø5.0

[mm]

Fixture Part		
Diameter(D)	Length(L)	Magic Cuff(C)
Ø5.0	7	2
		3
		4
		5
	9	2
		3
		4
		5
	11	2
		3
		4
		5

Code	Cuff
551M5007	1
552M5007	2
553M5007	3
554M5007	4
551M5009	1
552M5009	2
553M5009	3
554M5009	4
551M5011	1
552M5011	2
553M5011	3
554M5011	4

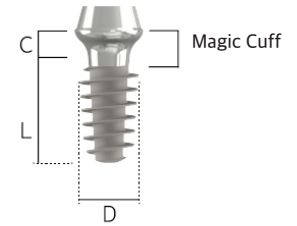

Fixture Diameter Ø5.5

[mm]

Fixture Part		
Diameter(D)	Length(L)	Magic Cuff(C)
Ø5.5	7	2
		3
		4
		5
	9	2
		3
		4
		5
	11	2
		3
		4
		5

Code	Cuff
551M5507	1
552M5507	2
553M5507	3
554M5507	4
551M5509	1
552M5509	2
553M5509	3
554M5509	4
551M5511	1
552M5511	2
553M5511	3
554M5511	4

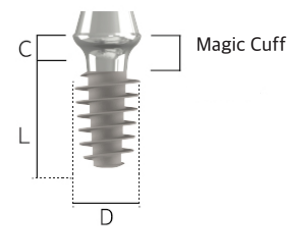

## MagiCore Fixture (uses Ø5.5 Abutment)

### Fixture Size

Fixture Diameter Ø6.0

[mm]

Fixture Part			Code	Cuff
Diameter(D)	Length(L)	Magic Cuff(C)		
Ø6.0	7	2	551M6007	1
		3	552M6007	2
		4	553M6007	3
		5	554M6007	4
	9	2	551M6009	1
		3	552M6009	2
		4	553M6009	3
		5	554M6009	4
	11	2	551M6011	1
		3	552M6011	2
		4	553M6011	3
		5	554M6011	4

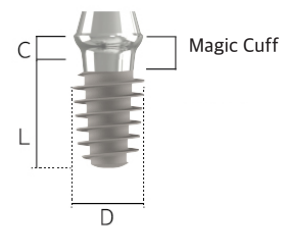

Fixture Diameter Ø6.5

[mm]

Fixture Part			Code	Cuff
Diameter(D)	Length(L)	Magic Cuff(C)		
Ø6.5	7	2	551M6507	1
		3	552M6507	2
		4	553M6507	3
		5	554M6507	4
	9	2	551M6509	1
		3	552M6509	2
		4	553M6509	3
		5	554M6509	4
	11	2	551M6511	1
		3	552M6511	2
		4	553M6511	3
		5	554M6511	4

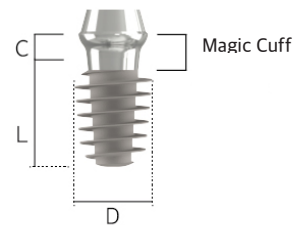

## MagiCore Prosthetic Components

### Healing Cap

Abutment Diameter	Color	Code
4.0	● Silver	MP CAP4,0
4.5	● Yellow	MP CAP4,5
5.5	● Silver	MP CAP5,5



■ 4.0 abutment available in selected regions only

### Lab Analog

Abutment Diameter	Color	Code
4.0	● Green	MPL40
4.5	● Yellow	MPL45
5.5	● Silver	MPL55



■ 4.0 abutment available in selected regions only

### Closing Screw

Abutment Diameter	Color	Code
4.0	● Green	HISC07
4,5/5,5	● Silver	HISC5



■ 4.0 abutment available in selected regions only

### Impression Coping (Transfer Type)

Abutment Diameter	Type	Height	Code
4.0	Hex	Short	● MTICH40
	Hex	Long	● MTICH40L
4.5	Hex	Short	● MTICH45
	Hex	Long	● MTICH45L
5.5	Hex	Short	● MTICH55
	Hex	Long	● MTICH55L

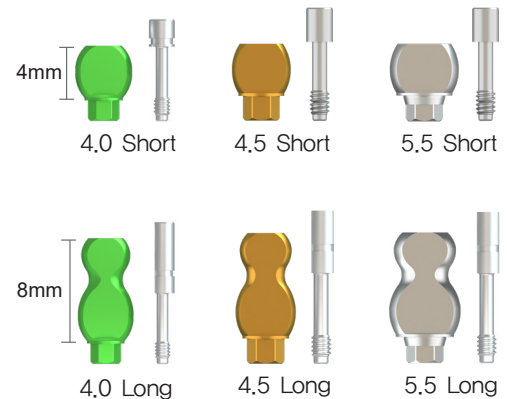

■ 4.0 abutment available in selected regions only

## MagiCore Prosthetic Components (continued)

### Impression Coping (Pick-Up Type)

Abutment Diameter	Type	Height	Code
4.0	Hex	Short	● MPICH40
	Hex	Long	● MPICH40L
4.5	Hex	Short	● MPICH45
	Hex	Long	● MPICH45L
5.5	Hex	Short	● MPICH55
	Hex	Long	● MPICH55L

■ 4.0 abutment available in selected regions only

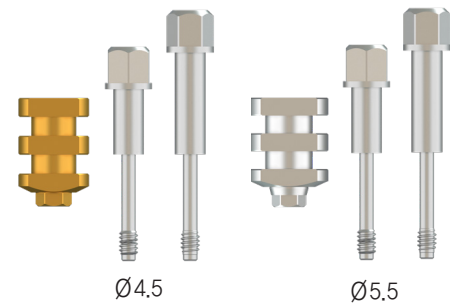
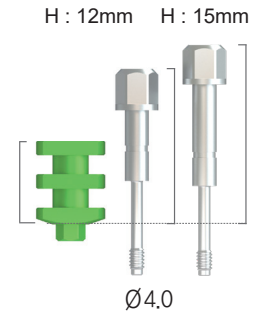

### Plastic Coping

Abutment Diameter	Type	Code
4.0	Hex	● MFPC40
4.5		○ MFPC45
5.5		● MFPC55

■ 4.0 abutment available in selected regions only



### Burn Out Core Cylinder (Screw-Retained Type)

Abutment Diameter	Type	Color	Code
4.0	Hex	● Green	MPSR40ST
	Non-Hex		MPSR40BT
4.5	Hex	○ White	MPSR45ST
	Non-Hex		MPSR45BT
5.5	Hex	● Black	MPSR55ST
	Non-Hex		MPSR55BT

· Tighten screw to 20N/cm

■ Special Order: ø5.0 / ø6.0

■ 4.0 abutment available in selected regions only



## MagiCore Prosthetic Components (continued)

### Burn Out Core Cap (Cemented Type)

Abutment Diameter	Type	Color	Code
4.0	Hex	● Green	MPLP40ST
	Non-Hex		MPLP40BT
4.5	Hex	○ White	MPLP45S
	Non-Hex		MPLP45B
5.5	Hex	● Black	MPLP55S
	Non-Hex		MPLP55B



- Special Order:  $\varnothing 5.0$  /  $\varnothing 6.0$
- 4.0 abutment available in selected regions only

### Short Abutment

Abutment Diameter	Height(H)	Type	
		Hex	Non-Hex
4.0	3	MMAH4003	MMAN4003
	5	MMAH4005	MMAN4005
4.5	3	MMAH4503	MMAN4503
	5	MMAH4505	MMAN4505
5.5	3	MMAH5503	MMAN5503
	5	MMAH5505	MMAN5505

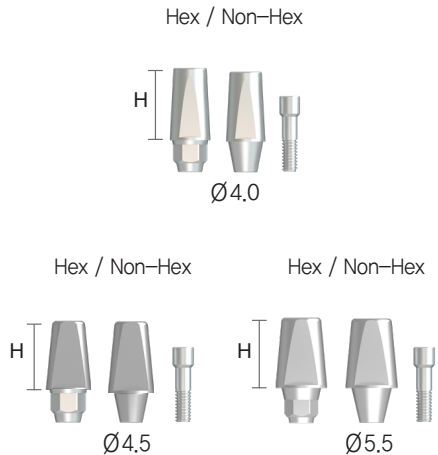

- Tighten screw to 20N/cm
- 4.0 abutment available in selected regions only

### MagiCore Solid Abutment

Abutment Diameter	Height(H)	Code
4.0	3	MA4003
	5	MA4005
4.5	3	MA4503
	5	MA4505
5.5	3	MA5503
	5	MA5505

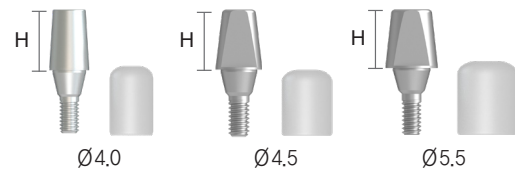

- Tightened with 1.2 Hex Driver at 20N/cm
- 4.0 abutment available in selected regions only

## MagiCore Prosthetic Components (continued)

### MagiCore Solid Abutment Lab Analog

Abutment Diameter	Height(H)	Code
4.5	3	● MAL453
	5	● MAL455
5.5	3	● MAL553
	5	● MAL555

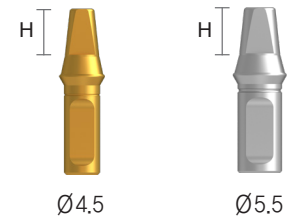

### MagiCore Solid Abutment Impression Cap

Abutment Diameter	Code
4.5	○ MSPC45
5.5	● MSPC55



## CAD / CAM Components

### MagiCore Scanbody

Abutment Diameter	Code
4.5	MSB45
5.5	MSB55

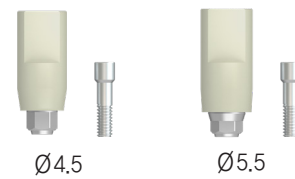

### MagiCore Link (Ti-base)

Abutment Diameter	Type	Code
4.0	Hex	MLH404
	Non-Hex	MLN404
4.5	Hex	MLH454
	Non-Hex	MLN454
5.5	Hex	MLH554
	Non-Hex	MLN554

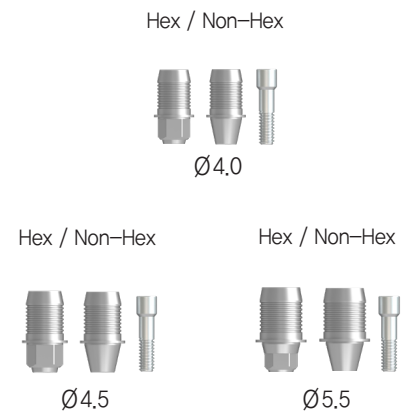

■ 4.0 abutment available in selected regions only

# For Minimally Invasive Implant Surgery

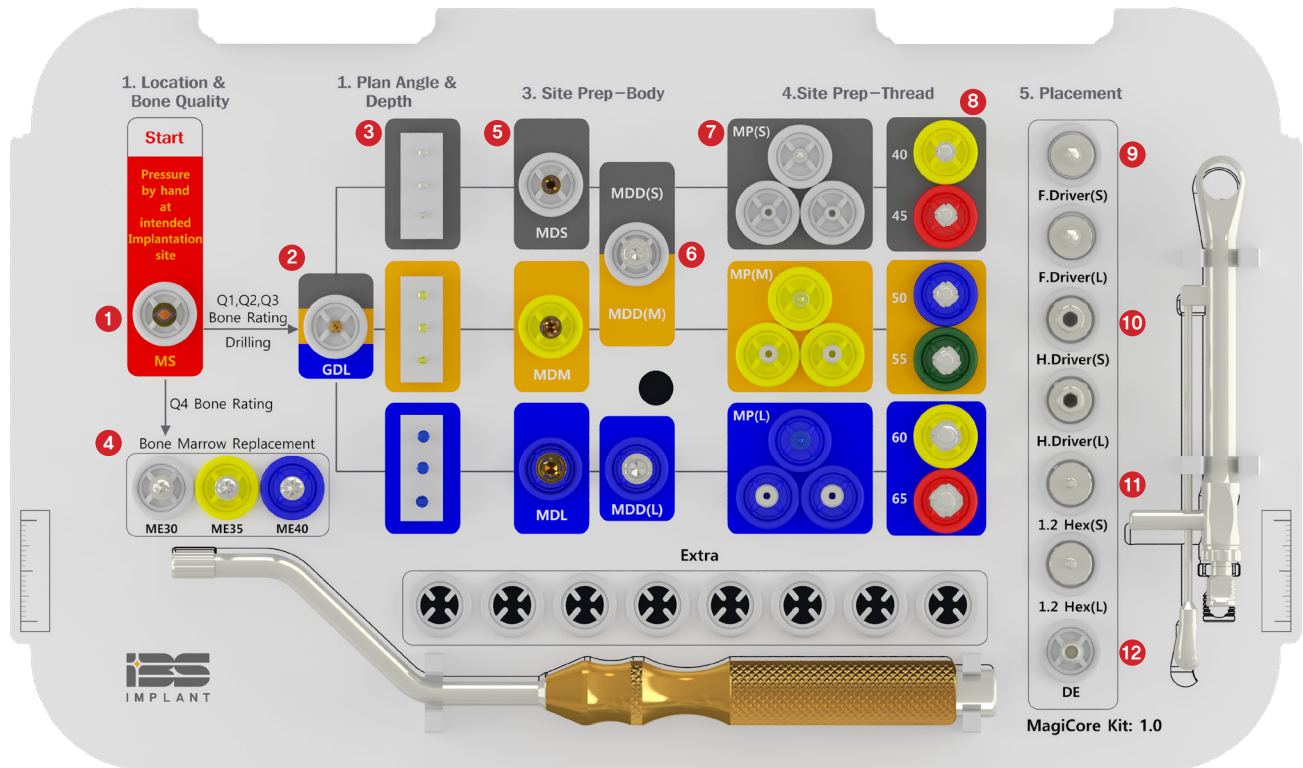

- |                     |   |
|---------------------|---|
| ① Magic Split       | ⑧ Magic Tap Drill (4.0/4.5/5.0/5.5/6.0/6.5) |
| ② Pin Drill         | ⑨ MagiCore Machine Driver                   |
| ③ Guide Pin         | ⑩ Ratchet Driver                            |
| ④ Magic Expander    | ⑪ 1.2 Hex Driver                            |
| ⑤ Magic Drill       | ⑫ Drill Extension                           |
| ⑥ Magic Depth Drill |   |
| ⑦ Magic Pin         |   |
| – Magic Body        |   |
| – Magic Tap Guide   |   |

## Magic Fit Drilling Tech.

The Magic Fit Drilling System is a state-of-the-art implant surgery system which allows for high precision from diagnosis to final placement. The tools used in each step allow for error-free drill path management, and create an osteotomy that minimizes bone removal and dramatically reduces damage to tissues during the process. The protocol makes early and immediate loading more predictable and practical.

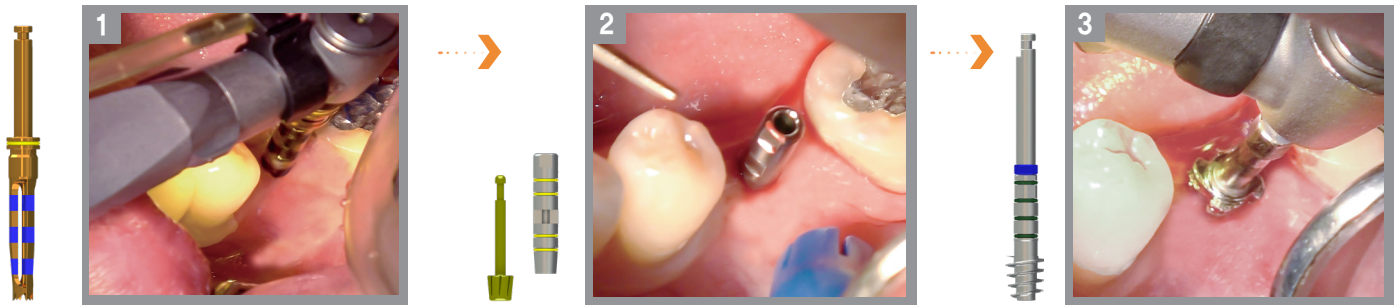

- Drill speed should be greater than 1,500~2,000rpm.
- Intermittent vertical pressure should be applied while maintaining direction (bone dancing).
- Do not apply Up & Down technique.
- Magic Tap Drill should be used at 20rpm and 40N/cm.

## B.E.B Tech. (Bone Expansion With Bending of Cortical Bone)

The B.E.B Tech. utilizes the biophysical properties of alveolar bone and a patented specially shaped instrument to safely and conveniently expand bone width and also lift the sinus up to 4mm without the need for grafting. This tech. is highly desirable by clinicians due to its ease of use and effectiveness in achieving desirable effects.

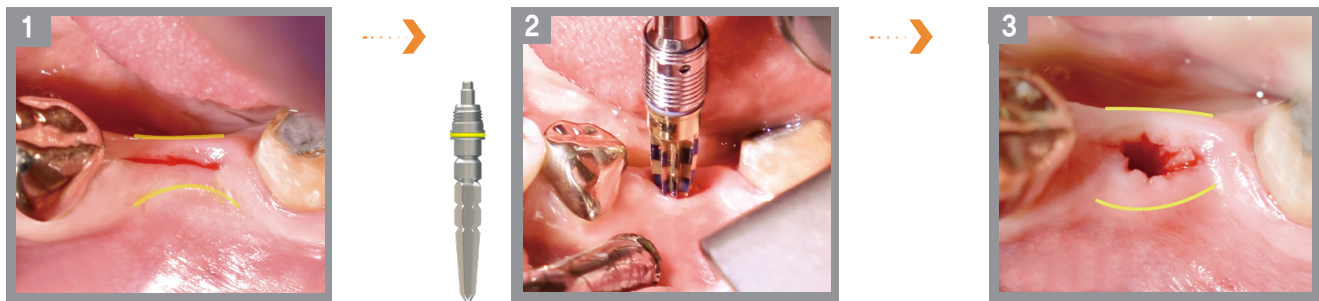

- 2-stage surgery is required and 5 months or more of healing should be allowed.
- If the buccal or lingual wall is too thin or cracks occur during procedure, bone grafting should be performed.
- Malleting should be done with light wrist action only.
- If the instrument shifts or does not advance, drilling should be done to remove dense bone areas before reapplying the Expander.

## C.M.C Tech. (Crestal Approach With Membrane Control)

The C.M.C Tech. is a minimally invasive crestal approach sinus augmentation technique which allows the clinician to directly control the exact height and volume of the membrane lift. Since the instrument lifts the membrane to a controlled height exactly above the placement site, there is no need for excessive bone graft material. Since a miniscule hole is formed to insert the instrument, there is even less chance for complications or failures.

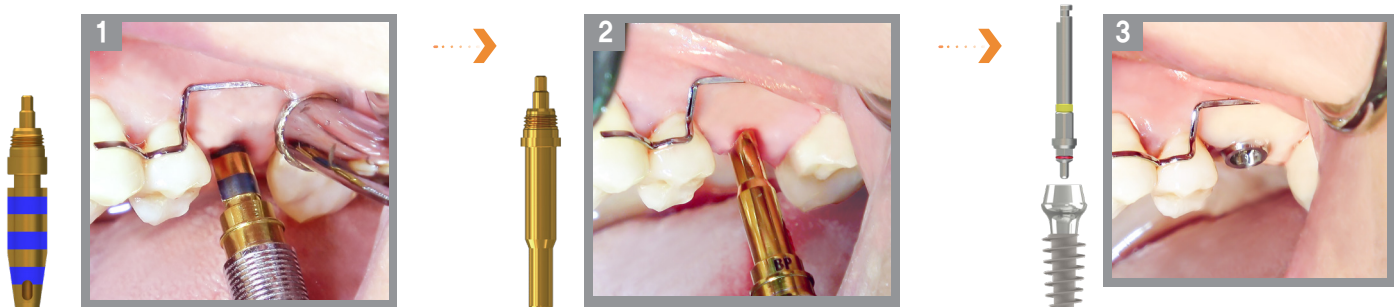

- Make such that the residual bone height is 2mm before applying the Magic Sinus Lifter.
- Malleting should be done with light wrist action only.
- Advance the instrument at a minimal velocity.
- If the instrument does not advance, use the Magic Drill to make further indentation before reapplying the Lifter.

## MagiCore Kit Components



### Magic Split

Diameter	Code
Ø2.5	MS25S

- Malleting instrument which connects to the Hand Lever.
- Used in the first step of implant surgery to determine bone quality.
- Used as an initial tool in cases when Magic Expanders are used for osteotomy.

### Optional

Ø2.5	MS25L
------	-------

- Long Type

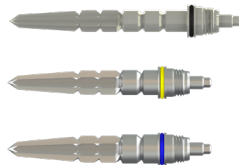

### Magic Expander

Diameter	Code
Ø3.0	● ME30
Ø3.5	● ME35
Ø4.0	● ME40

- Malleting instrument which connects to the **Hand Lever**.
- Main tools used for B.E.B Tech.
- Patented Star-shape design which reduces condensation forces and minimizes load to bone.



### Pin Drill

Length	Diameter	Code
29.5mm	Ø1.0	GDL

- Initial drill used in the first steps of the Fit Drilling Protocol, which makes space for the internal guide to be fixed in place.
- Makes space for Guide Pin to be fixed.

※ Drill in one-stroke and without Up & Down.

- Short Type

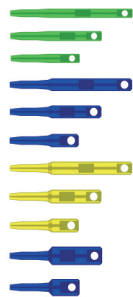

### Guide Pin

Diameter	Code
Ø2.3	● P23S/P23L
Ø3.3	● P33S/P33L
Ø3.8	● P38S/P38L
Ø4.8	● P48S/P48L

- Fixed in the space made by the **Pin Drill**.
- Serves as an initial path confirmation guide.
- Guides the **Magic Drill** internally, allowing for precise and convenient guided

### Optional (extra long)

Ø2.3	● P23EL
Ø3.3	● P33EL
Ø3.8	● P38EL

■ Ø2.3 available in selected regions only

## MagiCore Kit Components (continued)

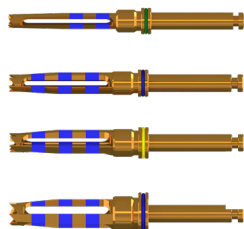

### Magic Drill

Diameter	Code
Ø2.3	● MDN
Ø3.3	● MDS
Ø3.8	● MDM
Ø4.8	● MDL

- Drill used to perform osteotomy in hard and soft bone types.
- Hollow design allows for autogenous bone harvesting.
- Recommended lifetime of use: 50 uses
- Recommended drill speed: +1,500rpm~2,000rpm.
- Excessive vertical force reduces cutting ability of drill.

### Optional

Ø4.3	MD43
Ø5.3	MD53
Ø5.8	MD58
Ø6.3	MD63

■ MDN available in selected regions only

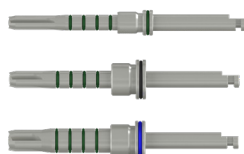

### Magic Depth Drill

Diameter	Code
Ø2.0	● MDDN
Ø2.4	● MDD
Ø3.1	● MDDW

- Blades only exist at the tip of the drill.
- Useful tool to determine the condition of the floor of osteotomy.
- In case of hard bone, drill can be used to drill deeper without affecting the shape of the osteotomy.
- Useful in confirming the final depth of osteotomy.

■ MDDN available in selected regions only

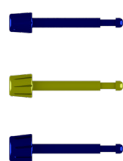

### Magic Tap Guide

Length	Diameter	Code
15mm	Ø2.36	● P4
15mm	Ø2.66	● P5
15mm	Ø3.3	● P6

- Used together with the Magic Body to form the Magic Pin.
- Useful for confirming the path and location of osteotomy.
- Guides the Magic Tap Drill, making for precise tap drilling.
- ※ Must not be used in presence of bone marrow space.

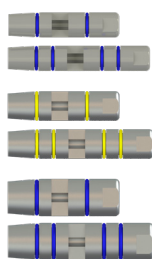

### Magic Body

Length	Diameter	Code
13.3mm	Ø2.98	● BS4
17.3mm	Ø2.98	● BL4
13.3mm	Ø3.49	● BS5
17.3mm	Ø3.49	● BL5
13.3mm	Ø4.33	● BS6
17.3mm	Ø4.33	● BL6

- Used together with the **Magic Tap Guide** to form the **Magic Pin**.
- Useful for confirming the path and location of osteotomy
- ※ Must be used after checking for presence of bone marrow space. If bone marrow exists, use without connecting with **Magic Tap Guide**.

## MagiCore Kit Components (continued)

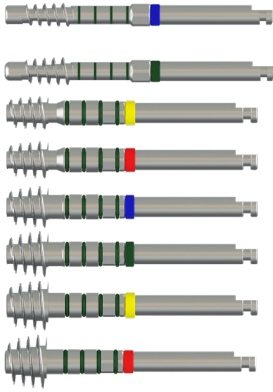

### Magic Tap Drill

Diameter	Code
Ø3.0	TD30
Ø3.5	TD35
Ø4.0	TD40
Ø4.5	TD45
Ø5.0	TD50
Ø5.5	TD55
Ø6.0	TD60
Ø6.5	TD65

· Used as a final step in "Fit Drilling", this drill forms the space for implant threads to follow.

· Set the motor at 20rpm and 40N/cm.

※ Do not apply vertical or lateral pressure during use.

■ TD30, TD35 available in selected regions only

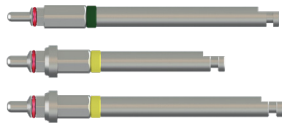

### MagiCore Machine Driver

Total Length	Diameter	Code
32mm	Ø2.9	MHMDNL
26mm	Ø3.7	MHMDS
33mm	Ø3.7	MHMDL

· Especially designed for MagiCore, this driver is compatible with both the handpiece and the **Ratchet Driver**.

■ MHMDNL available in selected regions only

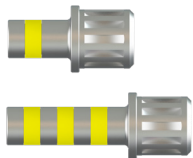

### Ratchet Driver

Diameter	Code	
Ø4.5	Short	RDS
Ø4.5	Long	RDL

· Used while connected to the **MagiCore Machine Driver** to place implant by hand. Can be connected to the **Torque Ratchet**.

### 1.2 Hexa Driver

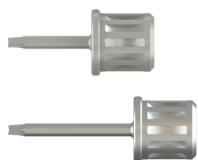

Length	Diameter	Code
17.5mm	Ø7.9	HD1,2S
22.5mm	Ø7.9	HD1,2L

· Used to tighten the Cover Screw and Abutment Screw.

· Can be connected to the Torque Ratchet.

※ Abutment Screws should be tightened to 20N/cm.

## MagiCore Kit Components (continued)



### Drill Extension

Code
DE

- Connected to the **Magic Drill** to extend its reach.



### Torque Ratchet

Length	Diameter	Code
82.9mm	Ø7.0	TRW

- Used to measure exact torque during placement by hand.
- Can measure up to 55N/cm.
- ※ Must be disassembled, cleaned and dried after use.

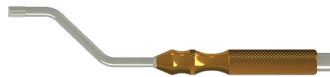

### Angled Hand Lever

Code
HLA

- Serves as a handle when connected to a malleting instrument.



### Bone Remover

Length	Code
100mm	BR

- Used to easily remove bone core from center of **Magic Drill**.



### IBS Spoon Excavator

Length	Code
166mm	EXC

- Laser marked to conveniently confirm depth while removing bone core from osteotomy.
- Used to examine the walls of osteotomy.
- Useful for minimally invasive GBR methods such as the Internal Pocket Tech.

## Additional Surgical Instruments

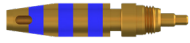

### Magic Sinus Lifter

Code
MSL

- Malleting instrument which connects to the Hand Lever.
- Used as a main instrument to perform C.M.C Tech.
- Patented design has hollow point which enables direct holding of bone block of sinus floor.
- Designed with double side blades which acts as a slowing mechanism.



### Bone Pusher

Code
BP

- Malleting instrument which connects to the **Hand Lever**.
- Used as a tool to insert graft material evenly into the sinus augmentation.



### 1.6 Guide Drill

Diameter	Code
Ø1.6	1.6GD

- Used as an initial drill in hard bone before applying the B.E.B Tech.
- Used to make a hole that guides the advancement of the Magic Split.



### Magic Marking Drill

Code
MMD
MMDW

- Used to conveniently mark the location of intended placement location.
- Instrument's diameter is 5mm, allowing it to be used as a convenient tool for sensing mesiodistal distance.

■ **Special Order**



### Magic Short Drill

Code
MSD

- Used in the posterior region when clearance is not enough to insert a normal drill length.
- Used as a convenient drill to prepare the bone before applying the C.M.C Tech.



### 2.8 Magic Drill

Diameter	Code
Ø2.8	MD28

- Used as an initial drill in hard bone before applying the B.E.B Tech.

## Additional Surgical Instruments (continued)

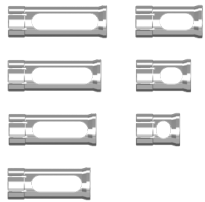

### Drill Stopper

Drilling Depth(mm)	Code
1	DS01
2	DS02
3	DS03
4	DS04
7	DS07
9	DS09
11	DS11

· Used as a safety guide for drill depth during osteotomy.

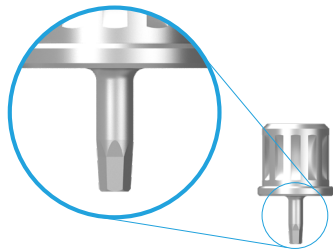

### Ultra Short 1.2 Hex Driver

Code
HD1.2US

· Used to remove the Coping Pin during impression coping.  
· Used for cases with low clearance.

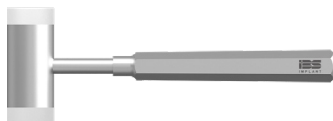

### IBS Mallet

Code
HM15

· Mallet used with Hand Lever instruments.  
※ Must use gentle tapping with wrist action only.

## Instructions for Connecting Malleting Instruments to the Hand Lever.

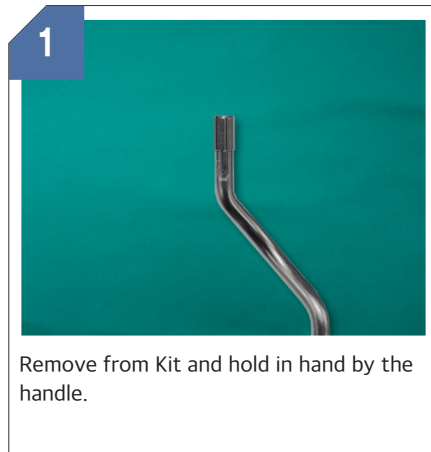

Remove from Kit and hold in hand by the handle.

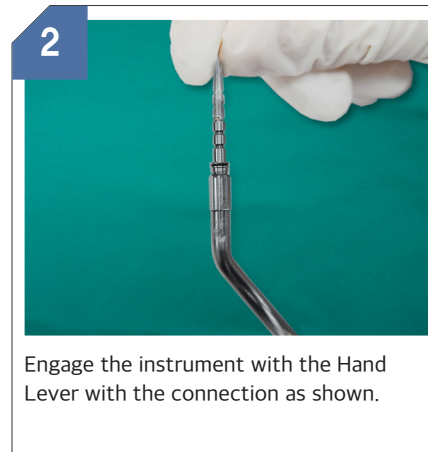

Engage the instrument with the Hand Lever with the connection as shown.

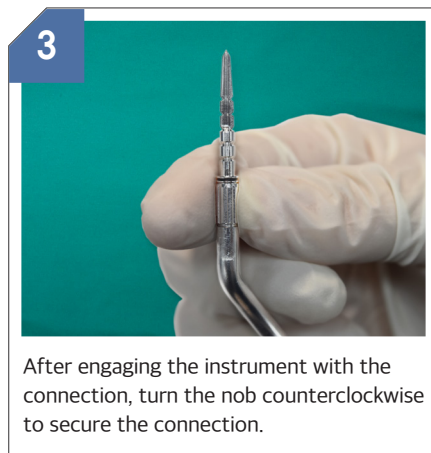

After engaging the instrument with the connection, turn the nob counterclockwise to secure the connection.

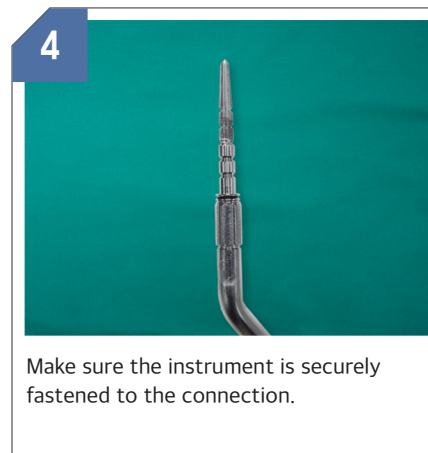

Make sure the instrument is securely fastened to the connection.

### Precautions when using the Magic Kit

- **Precaution when securing the malleting instrument to the Hand Lever**

- Do not apply excessive lateral force on the instrument after it is fastened.

- **Only use light wrist action when malleting. If the instrument does not advance into bone, use the Magic Drill to remove dense bone parts before reapplying the instrument.**

- **Immediately clean the instrument with cold water after use.**

- Do not use hydrogen peroxide or saline solution.
  - Ultrasonic cleaning is recommended. (Use a bar stand so that the blades of the instruments do not touch and damage each other.)

- **Store instruments in a dry place after cleaning.**

- If stored in a hot humid place, instruments may experience corrosion.

# MagiCore

## Protocol for Use

The MagiCore system was developed with a whole new concept, different from traditional implant systems. It follows that the surgical protocols are significantly different as well. In many cases, when clinicians who are familiar with traditional implant surgical protocols use MagiCore for the first few times, they tend to use the traditional surgical habits, which can damage the inter-thread bone of the MagiCore implant. Until the clinician is fully familiar with the MagiCore Surgical and Placement Method, we recommend that longer healing time is given before prosthetic loading. This extended healing time will ensure that if the inter-thread bone had been damaged, the bone can be fully remodeled and ready for loading.

## MagiCore Placement Planning

### 1. Determination of Placement Location

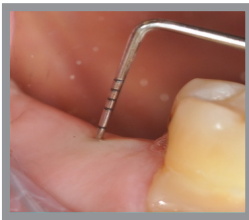

With minimally invasive implant surgery, we must take into account the mobility of the soft tissue around the implant once the implant has been placed. This is because if the gingiva around the implant is mobile after treatment, the ideal biologic width against the surface of the abutment will detach, and cause an undesirable periodontal result.

Thus, after calculating the prediction of the location of placement, evaluate the soft tissue at the site by using the Periodontal Probe to probe the gingiva 2mm buccal(labial) from the center of that location, and pull on the buccal mucosa to check for soft tissue mobility.

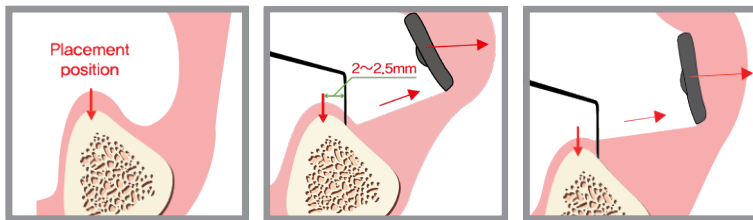

→ If there is no mobility of the gingiva, the location is suitable for flapless implantation and healthy perio conditions can be maintained after placement even without the presence of keratinized gingiva.

We can skip this step if plenty of keratinized gingiva is present in the proposed placement site.

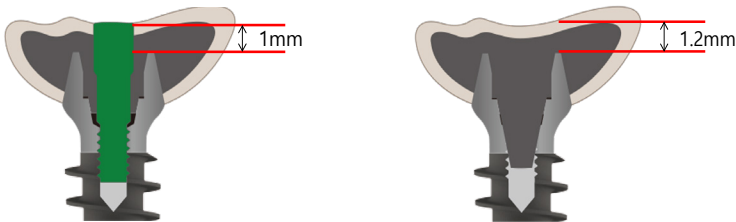

### Verification of Vertical Dimension

Measure the vertical dimension from the proposed placement location to the opposing tooth.

The vertical dimension is enough if this measurement is 3.5mm or greater. If not, move the placement location so that this constraint is met.

### 2. Determination of Osteotomy Method (according to bone quality)

- Using hand pressure only, apply Magic Split to the proposed placement location and push with light hand pressure.
- If the Magic Split enters into the bone without resistance and as far as 4mm into the bone, Drilling should not be used for the osteotomy. Rather, Magic Expanders should be used to perform Bone Marrow Replacement, as this bone is determined to be very soft (D4).
- If the Magic Split does not enter into the bone more than 2mm by force of hand only, this location is determined to be suitable for the Fit Drilling and Fit Implantation Method.

### 3. Determining the Shape and Path of Alveolar Bone at Placement Site

· Determining The Path of Pin Drilling

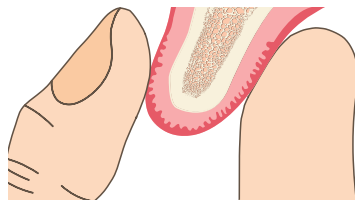

Palpate the alveolar bone with the thumb and forefinger to feel the path and shape of the bone. In addition, the shape of the alveolar bone can be evaluated by using the needle of the anesthetic syringe to penetrate the gingiva along the intended implantation site.

· Pin Drilling Method

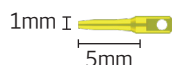
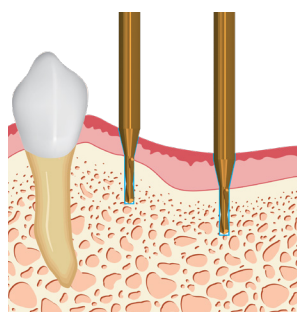

Guide Pin

Pin Drill

While running at 1,500~2,000rpm, use the Pin Drill just enough to penetrate the cortical bone.

Drill in one stroke, and do not apply Up & Down technique, in order to prevent occurrence of non-fixation of Guide Pin.

### 4. Installation of Guide Pin and CBCT Scan

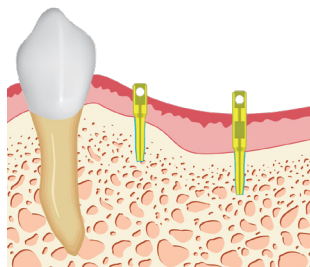
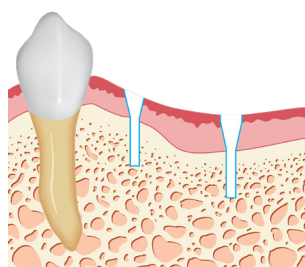

Fix the Guide Pin in the drilled site and make sure that it is securely fixed.

If the Guide Pin does not enter, reapply the Pin Drill and try again.

With the Guide Pin securely in place, take CBCT, analyze the scan for correctness of path, and make slight adjustments if needed by reapplying the Pin Drill.

### 5. Selection of the MagiCore Implant Diameter and Length

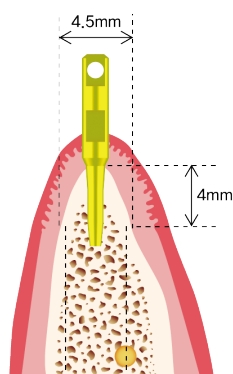

While examining the CT scan, measure the buccolingual bone width in 1mm increments down to 4mm from the crest.

- bone width 4.5mm = MagiCore Ø 4.0mm or less possible
  - bone width 5.5mm = MagiCore Ø 5.0mm or less possible
  - bone width 6.5mm = MagiCore Ø 6.0mm or less possible
- Bone width - 0.5mm = Possible diameter of MagiCore

※ Use 4.0, 5.0, 6.0 as first choice diameter.

With soft bone, 4.5, 5.5, 6.5 diameters can be used as a secondary choice.

Select a suitable implant length, taking into consideration the location of anatomical structures. The length of the MagiCore fixture should be determined from the level at which the bone width is sufficient. (left figure example: level at which bone width is 4.5mm)

## 6. Diagnosis of Soft Tissue Thickness

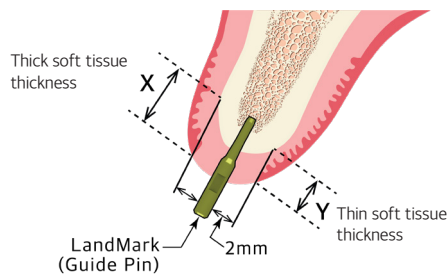

From the determined placement location (where Guide Pin is now fixed), probe the depth of the soft tissue 2mm away at 4 points (mesial, distal, buccal, lingual). The greatest depth measurement is determined to be the Soft Tissue Thickness.

※ **Note:** The surface of the gingiva is not always flat, and that the gingiva on the buccal tends to be relatively thicker, and that the bone level rests relatively lower on the buccal compared to the lingual.

## 7. Selecting the Magic Cuff Height and the Drilling Depth

Note: Placing MagiCore using the minimally invasive method allows us to predict the gingival outcome because the shape of the gingiva shows little to no change after placement.

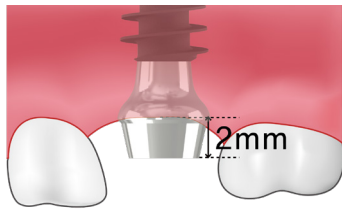

1) Non-Aesthetic Zone (Posterior)  
(By standard, select Magic Cuff Height equal to the Soft Tissue Thickness)

- Prosthetic Margin: Positioned at the buccal gingival margin  
Magic Cuff height = Soft Tissue Thickness
- Drill Depth (starting from the buccal gingival margin) that is,  
Drill Depth = fixture length + Soft Tissue Thickness

※ **Note:** Place such that the top platform of the Magic Post sits 2mm above the buccal gingival margin.

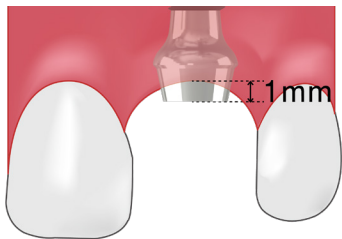

2) Aesthetic Region (Anterior)  
(By standard, select Magic Cuff height equal to 1mm less than the Soft Tissue Thickness, such that the Prosthetic Margin sits 1mm below the labial gingival margin.)

- Prosthetic Margin: Positioned 1mm below the labial gingival margin  
Magic Cuff height = Soft Tissue Thickness - 1mm
- Drill Depth (starting from the labial gingival margin) that is,  
Drill Depth = Fixture length + Soft Tissue Thickness

※ **Note:** Place such that the top platform of the Magic Post sits 1mm above the labial gingival margin.

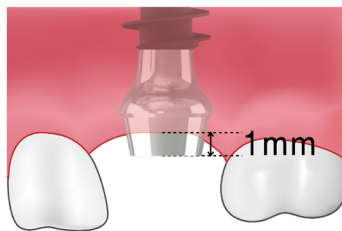

3) In Case of Immediate Placement after Extraction (posterior and anterior)  
(Similar to aesthetic regions, position the Prosthetic Margin 1mm below the buccal gingival margin)

- Prosthetic Margin: Positioned 1mm below the buccal gingival margin.  
Magic Cuff height = Soft Tissue Thickness - 1mm
- Drill Depth (starting from the buccal gingival margin) that is,  
Drill Depth = Fixture length + Soft Tissue Thickness

※ **Note:** Place such that the top platform of the Magic Post sits 1mm above the buccal gingival margin.

### Tip:

- The Magic Cuff Height is always selected after measuring the Soft Tissue Thickness, and after determining the intended positioning of the Prosthetic Margin.
- Always measure the drill depth with the buccal(labial) gingival margin as the starting point of measurement.
- The positioning of the prosthetic margin should be measured relative to the buccal(labial) margin.

## 8. Fit Drilling

- Body Preparation (Main Osteotomy which removes bone in the shape of the core body of the MagiCore)

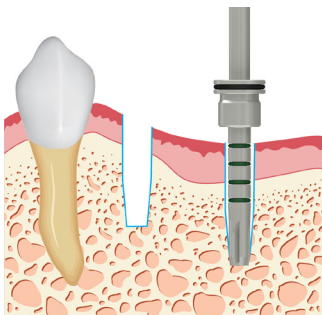
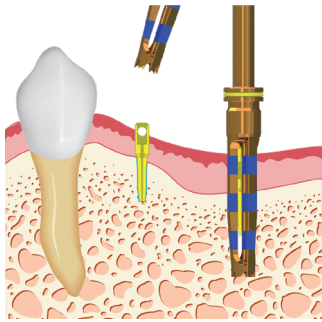

※ **Drilling is done in 2 stages.**

- First, engage the Magic Drill with the Guide Pin which fits the size of the intended MagiCore diameter, and drill 3~4mm into the bone.
- Then, remove the Magic Drill from the osteotomy and remove the Guide Pin from within the Magic Drill.
- Reapply the Magic Drill, regaining the same path as before and drill to intended final depth.
- Do not apply Up & Down technique. Apply intermittent pressure while maintaining uniform path, adjusting pressure to the resistance of bone density conditions.
- Keep in mind that the Final Drill Depth is equal to the Soft Tissue Thickness + the length of the chosen MagiCore implant with the starting point of measurement being the buccal(labial) gingival margin.
- After drilling with Magic Drill is complete, remove bone core from osteotomy using the Spoon Excavator, if needed.

※ **Note:** Drill speed should be 1500~2000rpm or more. No Up & Down. Only intermittent pressure.

- Apply the Magic Depth Drill and drill to the predetermined final osteotomy depth.
- Confirm the final depth of osteotomy starting from the buccal (labial) gingival margin.
- Apply the Spoon Excavator and feel the walls of the osteotomy to check for existence of bone marrow spaces or bone perforations.

## 9. Thread Preparation

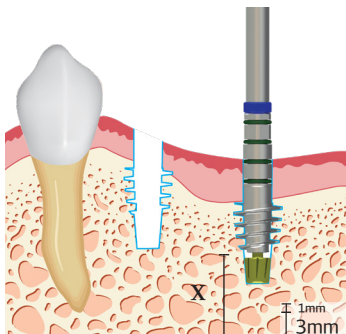
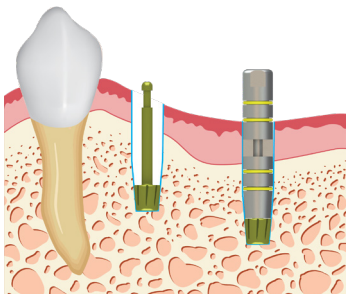

1) Reconfirming The Path of Osteotomy

- Connect the Magic Tap Guide with the Magic Body to form the Magic Pin.
- Install the Magic Pin into the osteotomy by inserting to the depth of osteotomy.  
Note: always measure starting from the buccal (labial) gingival margin.
- Confirm the path of the osteotomy.

※ **Note:** In cases involving the sinus, or in the presence of bone marrow spaces, only use the Magic Body (not together with the Magic Tap Guide).

2) Using the Magic Tap Drill

- Set the motor at 20rpm and 40N/cm.
- Once the path is set, apply force only to maintain this decided path.
- Advance the Magic Tap Drill to 5mm within bone, making sure not to apply vertical force. (this step is able to further indicate bone quality around the osteotomy).
  - a) if the Tap advances easily to 5mm within bone, place predetermined MagiCore.
  - b) if the motor stops automatically before reaching 5mm into bone, engage Tap Drill with the Ratchet Driver and Tap the rest of the osteotomy by hand. (up to 2mm from the apex of the osteotomy)
- Fit Drilling is complete.

※ **Note:** Depth of Magic Tap Drill with the Magic Tap Guide fixed within the osteotomy:  
 Depth of Magic Tap Drill = Final Depth of Osteotomy - 4mm  
 (\*this 4mm refers to a depth keeping a safe 1mm distance from the top of the Tap Guide pin head.

## 10. Fixture Placement

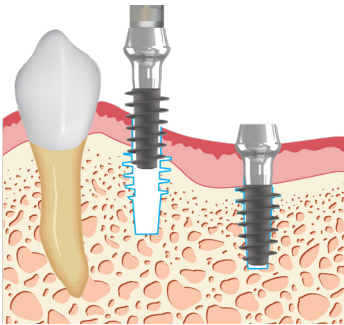

- The pre-made thread tracks in the bone must be engaged by the MagiCore threads and the implantation must be done passively by hand, unless Fit Drilling Technique was not used. (i.e. D4 bone)
- Initially, make contact with the gingiva and the implant while rotating the implant counterclockwise and apply pressure until the implant reaches the osteotomy.
- While rotating counterclockwise, a point when the threads engage with the tapped thread space can be felt. Upon this point, rotate the implant clockwise to passively place the implant with the threads following in the pre-made thread path.
- Make sure to only place the implant to the predetermined depth. Do not try to over-rotate the implant to gain a higher final torque.

※ **Note:** The inter-thread bone should not be damaged.  
Thus, in Fit Implantation, the implant must be placed passively by hand only.

**Chart for Selection of MagiCore Diameter and Their Matching Tool Sizes**

Buccolingual Bone Width	Placement Fixture (ø)	Guide Pin	Magic Drill	Magic Depth Drill	Magic Tap Guide	Magic Tap Drill
3,5mm or more	3.0	GP(N)	MD(N)	MDD(N)		3.0
4,0mm or more	3,5					3,5
4,5mm or more	4,0	GP(S)	MD(S)	MDD(M)	MP(S)	4,0
5,0mm or more	4,5					4,5
5,5mm or more	5,0	GP(M)	MD(M)		MP(M)	5,0
6,0mm or more	5,5					5,5
6,5mm or more	6,0	GP(L)	MD(L)	MDD(L)	MP(L)	6,0
7,0mm or more	6,5					6,5

**Surgical Instrument Size and Measuring Chart**

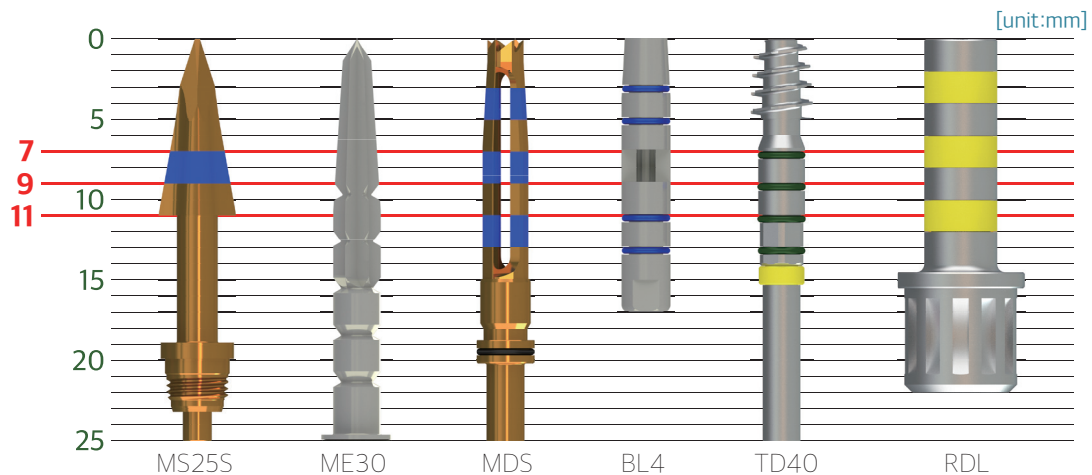

• Maintenance after Placement •

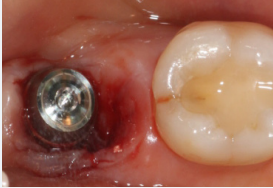

In minimally invasive treatments, the Essix appliance(retainer) is used to protect the wound.

- To preserve blood clot after placement: 3 weeks
- To preserve stability in very soft bone: 4 weeks
- To preserve shape after minimally invasive bone grafting: 12 weeks

**MAGICORE<sup>®</sup>**

THE WORLD'S FIRST  
MINIMALLY INVASIVE IMPLANT



## Product Line

MagiCore

MagiCore KIT

MagiCore Narrow



**IBS IMPLANT HQ, KOREA:** 44-19, Techno 10-ro, Yuseong-gu, Daejeon, Korea TEL +82 70 4865 3130 FAX +82 42 933 2881 E-MAIL: [info@ibsimplant.com](mailto:info@ibsimplant.com)

**IBS of America, California, USA:**  
3860 El Dorado Hills Blvd., El Dorado Hills, CA 95762  
TEL +1 844 694 2787 E-MAIL: [info@ibsofamerica.com](mailto:info@ibsofamerica.com)

**IBS of China, Qingdao, China:**  
Chongqing North Road 191-1, Chengyang District, Qingdao, China  
TEL +86 532 67731041 E-MAIL: [info@ibsimplant.com](mailto:info@ibsimplant.com)

**IBS of Europe, Roanne, France:**  
1 Rue Carnot, 42120 Le Coteau, France  
TEL +33 4 77 69 33 20 E-MAIL: [info2@ibsimplant.com](mailto:info2@ibsimplant.com)